

REP	N° DAK	Description	QTE
1	07.002772-C	CHAUFFE EAU SOLAIRE 201-29H_V20	1
2	07.002547-C	KIT SUP PT CESI 201-29H_V20	1

REVISIONS		
REV	DESCRIPTION	DATE
		xx/xx/20xx



Informations contained in this drawing are the sole properties of DAK INDUSTRIES. Reproduction in part or whole without the written permission is prohibited.

LINEAR DIMENSIONS ARE IN MILLIMETERS. ANGULAR DIMENSIONS ARE IN DEGREES. GENERAL TOLERANCES ACCORDING TO:
-

MATERIAL :
-
FINISH :
-
WEIGHT : 119 Kg
NAME : CESI 201-29H_V20 PT GRIS 9007

NAME	DATE & SIGNATURE
DESIGNER J.BRIARD	
CHECKER F.MYKIETA	
METHODS E.JEFFREDO	
SCALE : 1:15 SIZE : A3 CREATION DATE : 03/04/2021	N° DAK INDUSTRIES REVISION : 07.002553 - C STATUS : STANDARD
	PAGE: 1/1

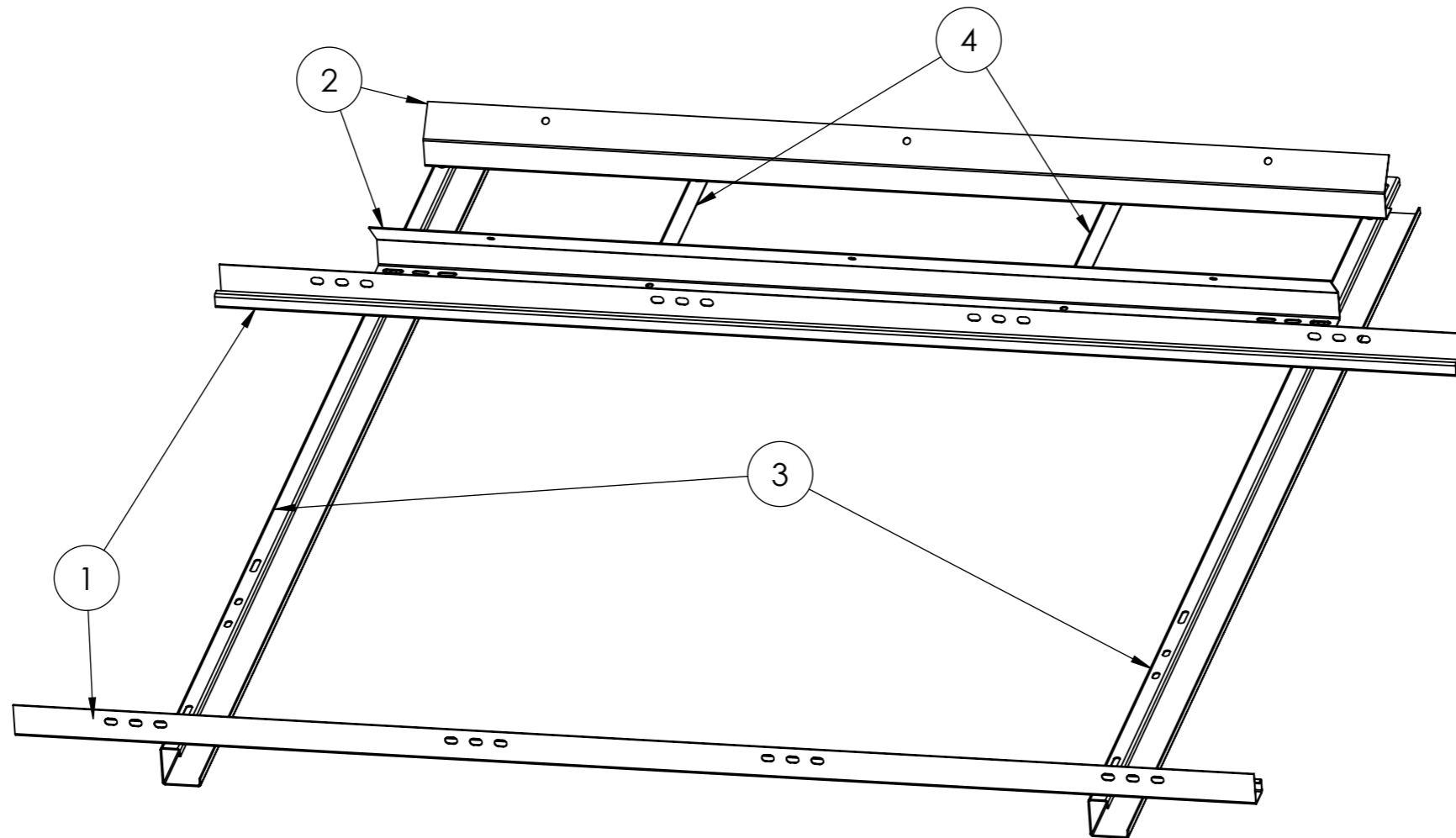

REP	N° DAK	DESCRIPTION	QTE
1	07.002247-C	TRAVERSE SUPPORT CAPTEUR 2006	2
2	07.002801-C	TRAVERSE SUPPORT BALLON 200L LG1500	2
3	07.001608-C	LONGERON BALL CAPT LG2060	2
4	07.002813-C	RACCORD TRAVERSE - JONCTION	2

REVISIONS		
REV	DESCRIPTION	DATE
		xx/xx/20xx

DAK INDUSTRIES

Informations contained in this drawing are the sole properties of DAK INDUSTRIES. Reproduction in part or whole without the written permission is prohibited.

LINEAR DIMENSIONS ARE IN MILLIMETERS. ANGULAR DIMENSIONS ARE IN DEGREES. GENERAL TOLERANCES ACCORDING TO:

MATERIAL : - FINISH : -

WEIGHT : 27 Kg NAME : KIT SUP PT CESI 201-29H_V20

NAME	DATE & SIGNATURE
DESIGNER J.BRIARD	
CHECKER F.MYKIETA	
METHODS E.JEFFREDO	
SCALE : 1:10 SIZE : A3 CREATION DATE : 01/04/2021	N° DAK INDUSTRIES REVISION : 07.002547 - C STATUS : STANDARD
	PAGE: 1/3

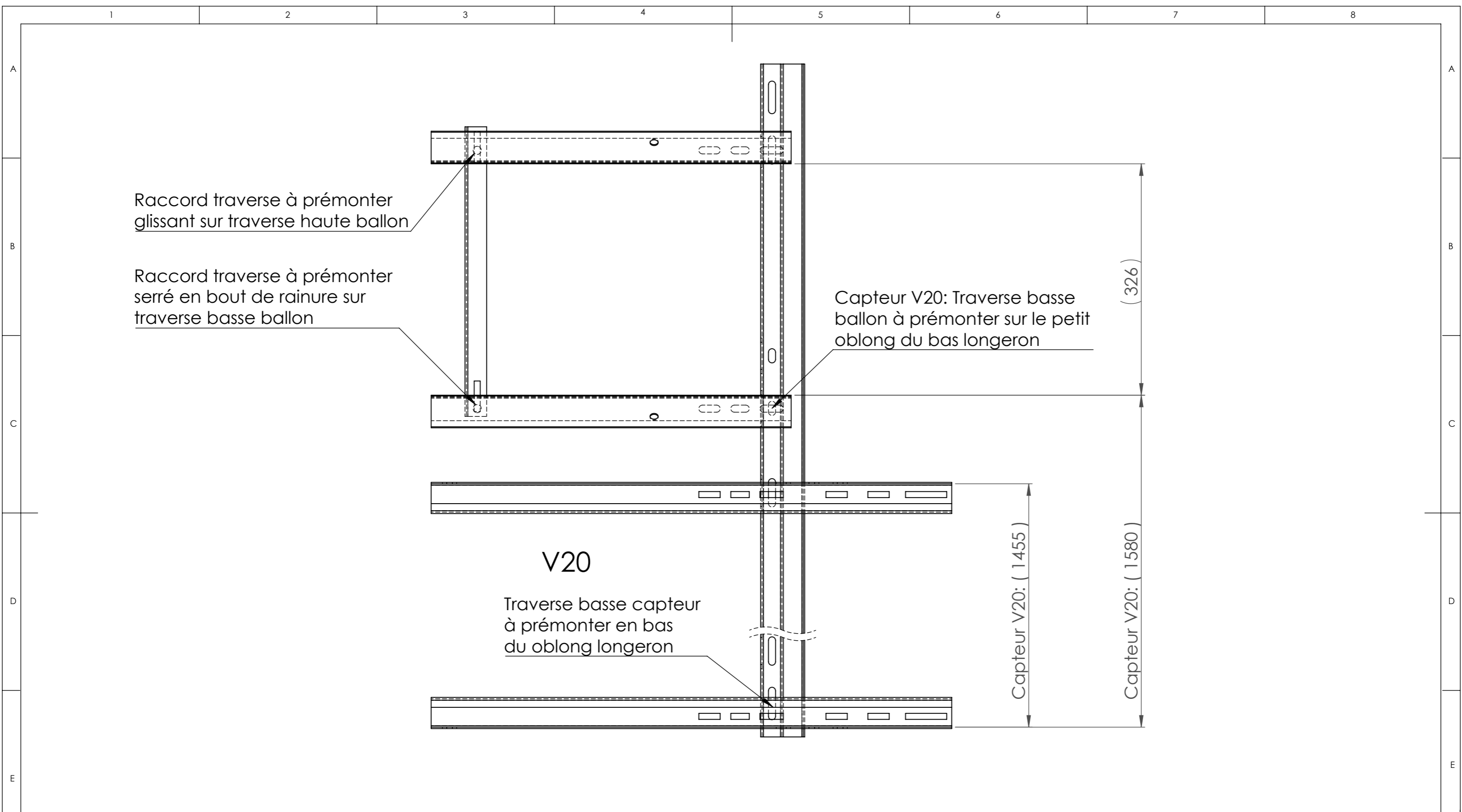

REVISIONS		
REV	DESCRIPTION	DATE
		xx/xx/20xx

DAK INDUSTRIES

Informations contained in this drawing are the sole properties of DAK INDUSTRIES. Reproduction in part or whole without the written permission is prohibited.

LINEAR DIMENSIONS ARE IN MILLIMETERS. ANGULAR DIMENSIONS ARE IN DEGREES. GENERAL TOLERANCES ACCORDING TO:

MATERIAL : - FINISH : -

WEIGHT : 27 Kg NAME : KIT SUP PT CESI 201-29H_V20

NAME	DATE & SIGNATURE
DESIGNER J.BRIARD	
CHECKER F.MYKIETA	
METHODS E.JEFFREDO	
SCALE : 1:5 SIZE : A3 CREATION DATE : 01/04/2021	N° DAK INDUSTRIES REVISION : 07.002547 - C STATUS : STANDARD
	PAGE: 2/3

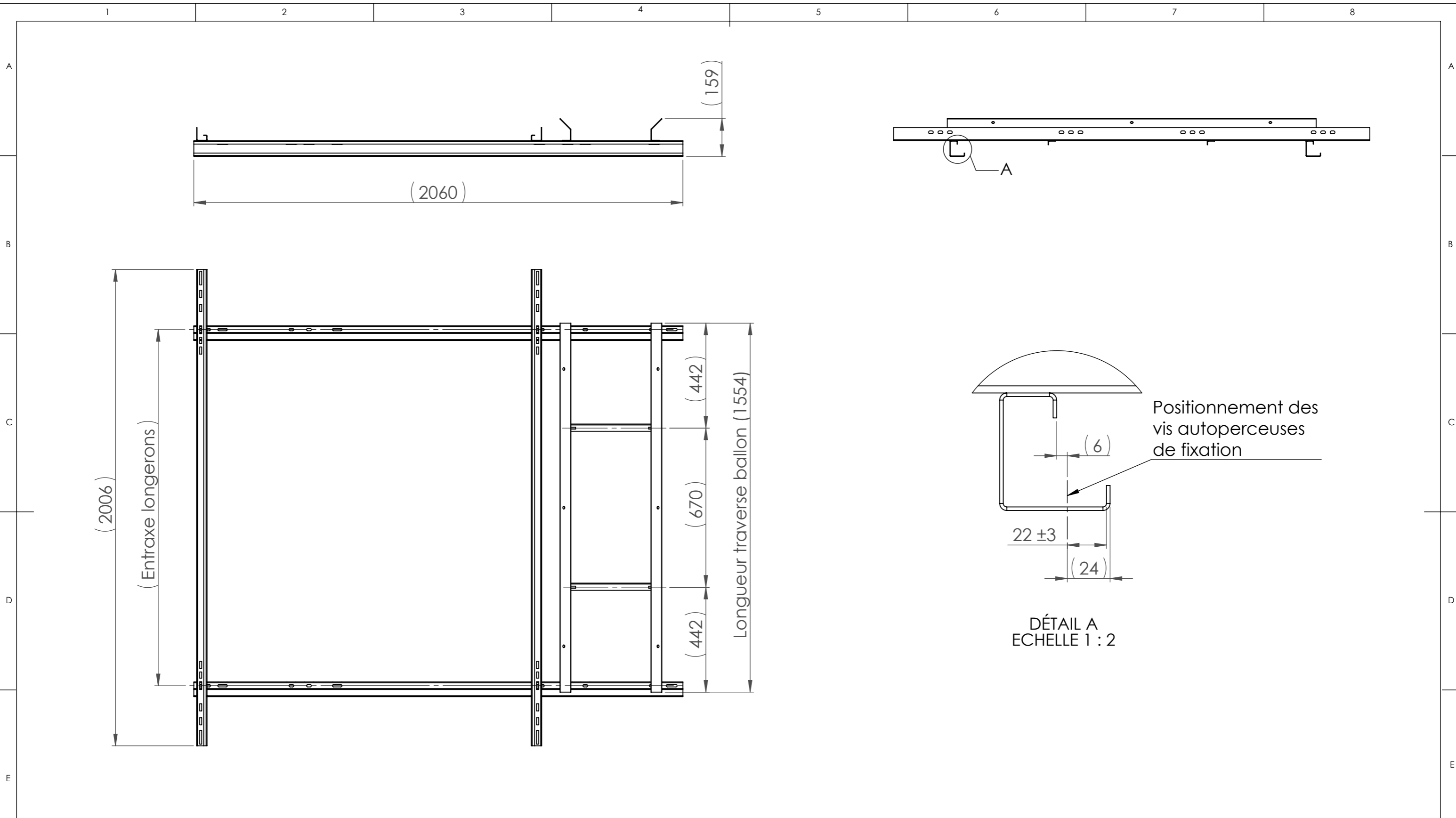

REVISIONS		
REV	DESCRIPTION	DATE
		xx/xx/20xx

DAK INDUSTRIES

Informations contained in this drawing are the sole properties of DAK INDUSTRIES. Reproduction in part or whole without the written permission is prohibited.

LINEAR DIMENSIONS ARE IN MILLIMETERS. ANGULAR DIMENSIONS ARE IN DEGREES. GENERAL TOLERANCES ACCORDING TO:

MATERIAL : - FINISH : -

WEIGHT : 27 Kg NAME : KIT SUP PT CESI 201-29H_V20

DESIGNER	NAME	DATE & SIGNATURE
J.BRIARD		
F.MYKIETA		
E.JEFFREDO		
SCALE : 1:15	N° DAK INDUSTRIES REVISION :	
SIZE : A3	07.002547 - C	
CREATION DATE : 01/04/2021	STATUS : STANDARD	
		PAGE: 3/3